



HOSHIZAKI

Premier K 3 A 3D 3D 3D L E 3-Section Refrigerated Counter

PRODUCT SERIES: PREMIER
ITEM NUMBER : 311000444100
COUNTRY OF ORIGIN : TURKEY



1/1 GN

OPTIONAL ACCESSORIES

- Set of legs 125-200 mm
- Set of legs 130-180 mm
- Set of castors Ø100 mm
- Set of castors Ø125 mm
- Set of castors Ø170 mm
- Castor Extension Kit (extends height of castors by 50 mm)
- Door section
- Drawer section with 2 x 1/2 drawers
- Drawer section with 3 x 1/3 drawers
- Soft-close drawer Conversion Kit (for retrofit)
- Flat worktop
- Flat worktop with 50mm splashback
- Flat worktop with 100mm splashback

Hoshizaki Premier K 3 A 3D 3D 3D L E is a 3-section 1/1 GN refrigerated counter with 3 drawer sections each with 3 x 1/3 drawers and a flat worktop. It has a net usable volume of 232 ltr. The body height is 750 mm.

- Fan assisted cooling
- Completely front vented
- Unit can be fully integrated. Due to front venting design, no air flow is required to the underneath, sides or back of unit
- Automatic defrost with re-evaporation of defrost water
- Heavy duty cabinet and compressor compartment construction
- Climate class 5 cooling system enduring up to +40°C ambient temperature
- Exterior and interior of stainless steel AISI 304
- A compact slide out refrigeration unit for maintenance and service
- Removable condenser filter for cleaning or replacement
- Compartmentalized cooling unit that is available as one unit
- Drawers with pull-out stop
- 3 x 1/3 drawer sets compatible with 150mm deep GN pans
- The cooling performance allows for drawer section next to compressor compartment
- Removable magnetic drawer gaskets with triple insulation area
- Pan-shaped inside base with rounded corners to catch fluids
- IPX2 water protection
- Matching design identity as the Premier cabinets

WARRANTY PERIOD

5 Years on Parts & Labour

EXTERIOR

Stainless steel AISI 304

INTERIOR

Stainless steel AISI 304

Refrigerant: R290 / Refrigerant (kg): 0.07
/ CO2 equivalent (kg) : 0.2

| Energy consumption (kWh/Year) | Energy Efficiency Index EEI | Energy Efficiency Class Standard | Energy Efficiency Class |
|-------------------------------|-----------------------------|----------------------------------|-------------------------|
| 525 | 22.02 | ISO 22041-2019 | A |

TECHNICAL CERTIFICATIONS



Hoshizaki Europe B.V.
Burgemeester Stramanweg 101,
1101 AA Amsterdam
The Netherlands

T: +31 (0)20 691 8499
F: +31 (0)20 691 8768
sales@hoshizaki.nl
www.hoshizaki-europe.com

For more information visit our website at
www.hoshizaki-europe.com
Hoshizaki Europe B.V. retains the right to change
products and their specifications without prior notice.



HOSHIZAKI

Premier K 3 A 3D 3D 3D L E 3-Section Refrigerated Counter

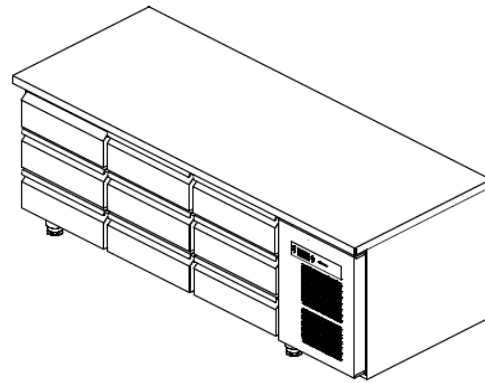
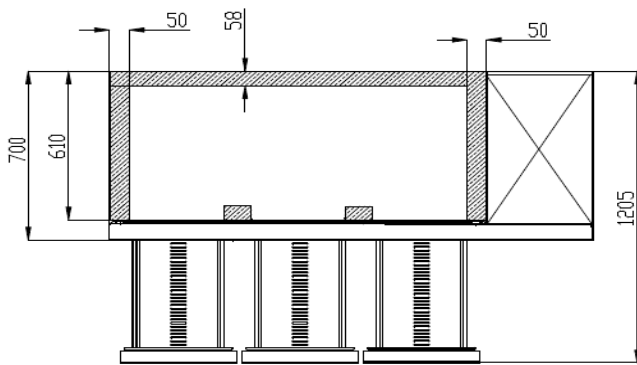
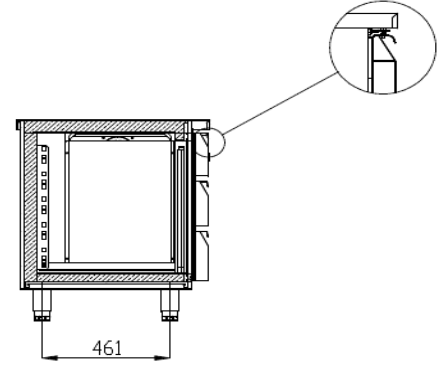
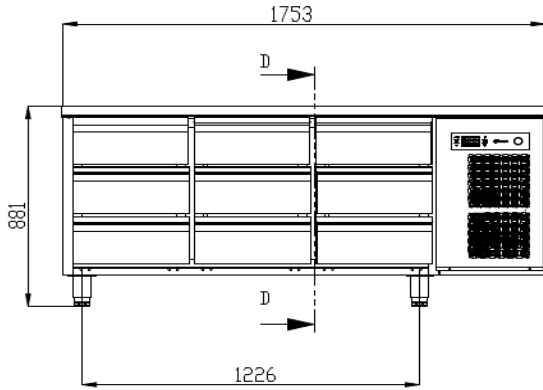

TECHNICAL SPECIFICATIONS

| Temperature range | GN or Shelf size | Volume, gross (ltr.) | Net usable volume (ltr.) | Power Supply | Connection load (Watt) | Ref. capacity at -10°C (Watt) | Insulation (mm) | Climate class | Sound Level - dB(A) |
|-------------------|------------------|----------------------|--------------------------|--------------|------------------------|-------------------------------|----------------------|---------------|---------------------|
| +2/+12°C | 1/1 GN | 463 | 232 | 230V, 50 Hz | 125 | 350 | 60 mm (polyurethane) | 5 | 43 |

SHIPPING SPECIFICATIONS

| Dimensions W x D x H (mm) | Net Weight (kg) | Dimensions Packed W x D x H (mm) | Weight, packed (kg) | Volume Packed (m3) |
|---------------------------|-----------------|----------------------------------|---------------------|--------------------|
| 1753 x 700 x 880/930 | 164 | 1783 x 730 x 1081 | 177 | 1.41 |

Disclaimer : Every effort has been made to ensure that the information contained in this spec sheet is accurate at the time of publishing. Hoshizaki Europe BV assumes no responsibility or liability for typographical errors or omissions or for any misinterpretation of the information within the publication and reserves the right to change without notice.



Hoshizaki Belgium:
Hoshizaki Denmark:
Hoshizaki Deutschland:
Hoshizaki France:
Hoshizaki Iberia:
Hoshizaki Italia:
Hoshizaki Middle East:

info@hoshizaki.be
info@hoshizaki.dk
vertrieb@hoshizaki.de
info@hoshizaki.fr
info@hoshizaki.es
info@hoshizaki.it
sales@hoshizaki.ae

Hoshizaki Netherlands:
Hoshizaki Norge:
Hoshizaki United Kingdom:
Hoshizaki Sverige:
Export Countries:
Other countries:

info@hoshizaki.nl
salg@hoshizaki.no
uksales@hoshizaki.uk
orderSE@hoshizaki.dk
sales@hoshizaki.nl
sales@hoshizaki.nl

www.hoshizaki-europe.com