



HOSHIZAKI

Premier FL 2 A DL DR L E 2-Section Freezer Counter

PRODUCT SERIES: PREMIER 270
ITEM NUMBER: 223000012100
COUNTRY OF ORIGIN: TURKEY



Hoshizaki Premier FL 2 A DL DR L E is a 2-section 1/1 GN freezer counter with 2 doors with door lock and a flat worktop. It has a net usable volume of 192 ltr. The shelf width is 325 mm.

- Fan assisted cooling
- Completely front vented
- Unit can be fully integrated. Due to front venting design, no air flow is required to the underneath, sides or back of unit
- Automatic defrost with re-evaporation of defrost water
- Heavy duty cabinet and compressor compartment construction
- Climate class 5 cooling system enduring up to +40°C ambient temperature
- Exterior and interior of stainless steel AISI 304
- A compact slide out refrigeration unit for maintenance and service
- Removable condenser filter for cleaning or replacement
- Compartmentalized cooling unit that is available as one unit
- Doors with lock
- Reversible doors
- Anti-tilt shelves
- Removable magnetic door gaskets with triple insulation area
- Pan-shaped inside base with rounded corners to catch fluids
- IP 2X water protection
- Matching design identity as the Premier cabinets



1 / 1 GN

ACCESSORIES INCLUDED

2 grey shelves per door section

OPTIONAL EXTRAS

- Set of legs 125-200 mm
- Set of legs 130-180 mm
- Set of castors 125 mm
- Set of castors 150 mm
- Set of castors 200 mm
- Castor Extension Kit (extends height of castors by 50 mm)
- Stainless shelf, 325 x 530 mm
- Grey shelf, 325 x 530 mm
- Shelf supports, 2 of
- Door section
- Flat worktop
- Flat worktop with 50 mm splashback
- Flat worktop with 100 mm splashback

WARRANTY PERIOD

**6 Years on Parts & Labour -
based on country agreement**

EXTERIOR

Stainless steel AISI 304

INTERIOR

Stainless steel AISI 304

Refrigerant type: R290 / Refrigerant: 0.055 kg / CO2 equivalent: 0.165 kg

CERTIFICATIONS



Energy consumption	Energy efficiency class	Energy efficiency class standard	Energy Efficiency Index (EEI)
1,410 kWh/year	C	ISO 22041: 2019	40.26 EEI



HOSHIZAKI

Premier FL 2 A DL DR L E

TECHNICAL SPECIFICATIONS

Temperature range	Shelf size	Volume, gross	Net usable volume	Volume, net	Power supply	Connection load	Climate class	Sound level	Ref. capacity (at -30°C)
-25/-5°C	1/1 GN	301 l	192 l	192 l	230V, 50Hz	425 W	5 (max. ambient 40°C w/ 40% RH)	45 dB(A)	376 W

SHIPPING SPECIFICATIONS

Width (packed)	Depth (packed)	Height (packed)	Volume (packed)	Gross weight	Width	Depth	Height	Net weight
1,340 mm	730 mm	1,081 mm	1.057 m3	112 kg	1,310 mm	700 mm	794.2 mm	100 kg

Disclaimer: Every effort has been made to ensure that the information contained in this spec sheet is accurate at the time of publishing. Hoshizaki Europe BV assumes no responsibility or liability for typographical errors or omissions or for any misinterpretation of the information within the publication and reserves the right to change without notice.

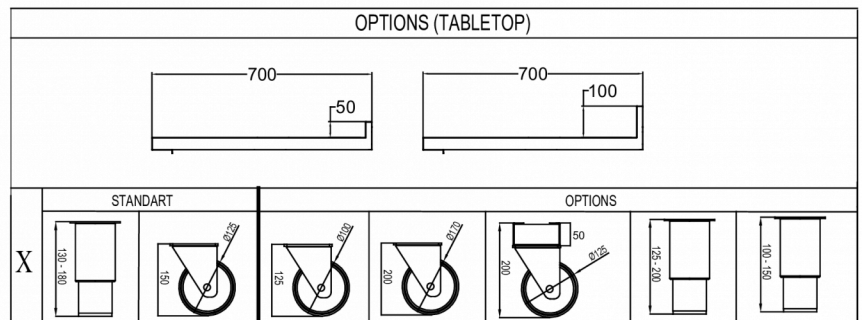
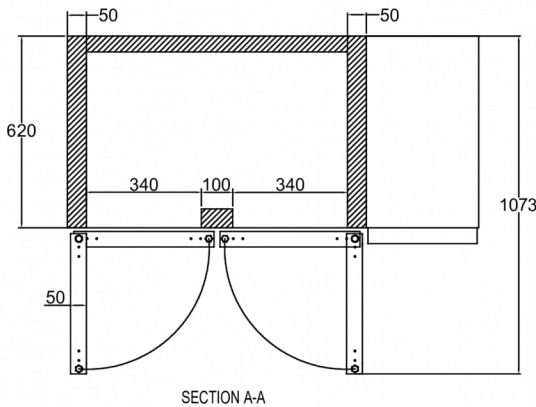
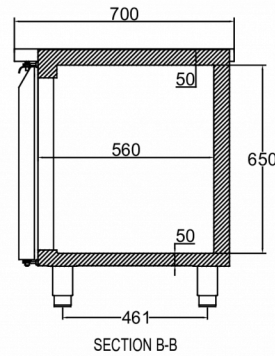
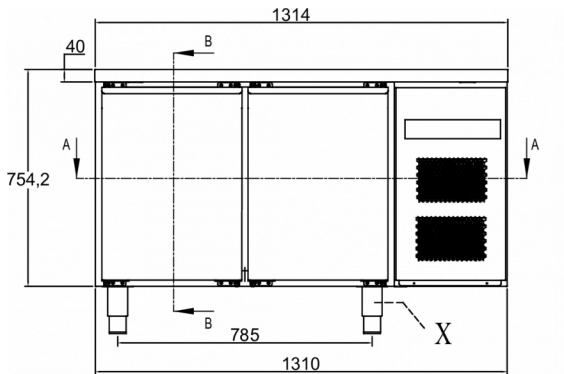

Hoshizaki Belgium
 Hoshizaki Danmark
 Hoshizaki Deutschland
 Hoshizaki France
 Hoshizaki Iberia
 Hoshizaki Italia
 Hoshizaki Middle East

info@hoshizaki.nl
info@hoshizaki.dk
vertrieb@hoshizaki.de
info@hoshizaki.fr
info@hoshizaki.es
commerciale@hoshizaki.it
sales.ex@hoshizaki-europe.com

Hoshizaki Netherlands info@hoshizaki.nl
 Hoshizaki Norge salg@hoshizaki.no
 Hoshizaki Sverige orderSE@hoshizaki.dk
 Hoshizaki UK uksales@hoshizaki.uk
 Export countries sales.ex@hoshizaki-europe.com
 Other countries sales.ex@hoshizaki-europe.com

www.hoshizaki-europe.com